

Panasonic®



PT-42P1

PT-37P1

Wide Plasma Display

Operating Instructions

PURCHASING GROUP

APR 06 2000

RECEIVED



The lightning flash with arrow-head within a triangle is intended to tell the user that parts inside the product are a risk of electric shock to persons.



The exclamation point within a triangle is intended to tell the user that important operating and servicing instructions are in the papers with the appliance.

IMPORTANT SAFETY INSTRUCTIONS IMPORTANT SAFEGUARDS

Read Instructions

All the safety and operating instructions should be read before the appliance is operated.

Retain Instructions

The safety and operating instructions should be retained for future reference.

Heed Warnings

All warnings on the appliance and in the operating instructions should be adhered to.

Follow Instructions

All operating and use instructions should be followed.

Attachments

Do not use attachments/accessories not recommended by the product manufacturer as they may cause hazards.

Grounding or Polarization

This product may be equipped with either a polarized 2-wire AC line plug (a plug having one blade wider than the other) or a 3-wire grounding-type plug, a plug having a third (grounding) pin.

The 2-wire polarized plug will fit into the power outlet only one way. This is a safety feature. If you are unable to insert the plug fully into the outlet, try reversing the plug. If the plug should still fail to fit, contact your electrician to replace your obsolete outlet. Do not defeat the safety purpose of the polarized plug. The 3-wire grounding-type plug will fit into a grounding type power outlet.

This is a safety feature. If you are unable to insert the plug into the outlet, contact your electrician to replace your obsolete outlet. Do not defeat the safety purpose of the grounding type plug.

Accessories

Do not place this product on an unstable cart, stand, pedestal, bracket, or table. The product may fall, causing serious injury to a child or adult, and serious damage to the appliance. Use only with a cart, stand, pedestal, bracket, or table recommended by the manufacturer, or sold with the product.

An appliance and cart combination should be moved with care. Quick stops, excessive force, and uneven surfaces may cause the appliance and cart combination to overturn.



S3125A

Power Sources

This product should be operated only from the type of power source indicated on the marking label. If you are not sure of the type of power supply to your home, consult your appliance dealer or local power company.

Unplug this apparatus during lightning storms or when unused for long periods of time.

Power-Cord Protection

Power-supply cords should be routed so that they are not likely to be walked on or pinched by items placed upon or against them, paying particular attention to cords at plugs, convenience receptacles, and the point where they exit from the appliance.

Overloading

Do not overload wall outlets and extension cords as this can result in a risk of fire or electric shock.

Object and Liquid Entry

Never push objects of any kind into this product through openings as they may touch dangerous voltage points or short-out parts that could result in a fire or electric shock. Never spill liquid of any kind on the product.

Servicing

Do not attempt to service this product yourself as opening or removing covers may expose you to dangerous voltage or other hazards. Refer all servicing to qualified service personnel.

Replacement Parts

When replacement parts are required, be sure the service technician has used replacement parts specified by the manufacturer or have the same characteristics as the original part. Unauthorized substitutions may result in fire, electric shock or other hazards.

Safety Check

Upon completion of any service or repairs to this product, ask the service technician to perform safety checks to determine that the product is in proper operating condition.

Damage Requiring Service

Unplug this product from the wall outlet and refer servicing to qualified service personnel under the following conditions:

- a. When the power-supply cord or plug is damaged.
- b. If liquid has been spilled, or objects have fallen into the product.
- c. If the product does not operate normally by following the operating instructions. Adjust only those controls that are covered by the operating instructions as an improper adjustment of other controls may result in damage and will often require extensive work by a qualified technician to restore the product to its normal operation.
- d. If the product has been dropped or the cabinet has been damaged.
- e. When the product exhibits a distinct change in performance - this indicates a need for service.
- f. If the product has been exposed to rain or water.

Cleaning

Unplug this product from the wall outlet before cleaning. Do not use liquid cleaners or aerosol cleaners. Use a damp cloth for cleaning.

Water and Moisture

Do not use this product near water - for example, near a bath tub, wash bowl, kitchen sink, or laundry tub, in a wet basement, or near a swimming pool, and the like.

Ventilation

Slots and openings in the cabinet are provided for ventilation and to ensure reliable operation of the product and to protect it from overheating, and these openings must not be blocked or covered. The openings should never be blocked by placing the product on a bed, sofa, rug, or other similar surface. This product should never be placed near or over a radiator or heat register. This product should not be placed in a built-in installation such as a rack unless proper ventilation is provided or the manufacturer's instructions have been adhered to.

Dear Panasonic Customer

Welcome to the Panasonic family of customers. We hope that you will have many years of enjoyment from your new Wide Plasma Display.

To obtain maximum benefit from your set, please read these Instructions before making any adjustments, and retain them for future reference.

Retain your purchase receipt also, and note down the Model Number and Serial Number of your set in the space provided on the rear cover of these Instructions.

Table of Contents

IMPORTANT SAFETY NOTICE	5	Flowchart of Menu	19
Safety Precautions	5	ASPECT Controls	20
Accessories	7	PICTURE POS./SIZE Controls	22
Accessories Supplied	7	SURROUND Controls.....	24
Optional Accessories	7	PICTURE MODE Controls	25
Remote Control Batteries.....	8	Picture Menu.....	26
Quick Start Guide.....	9	Sound Menu.....	28
Connections	9	Signal Menu	29
Connect the Plug to the Wall Outlet.....	10	Set up Menu.....	31
How to Turn the Power On.....	10	SERIAL terminal	32
Select the input signal.....	11	Troubleshooting.....	33
Basic Controls.....	12	Specifications.....	34
Connections	13		

FCC STATEMENT:

This equipment has been tested and found to comply with the limits for a Class A digital device, pursuant to part 15 of the FCC Rules.

These limits are designed to provide reasonable protection against harmful interference when the equipment is operated in a commercial environment.

This equipment generates, uses, and can radiate radio frequency energy and, if not installed and used in accordance with the instruction manual, may cause harmful interference to radio communications. Operation of this equipment in a residential area is likely to cause harmful interference in which case the user will be required to correct the interference at his own expense.

FCC CAUTION:

Pursuant to 47CFR, Part 15.21 of the FCC rules, any changes or modifications to this monitor not expressly approved by Matsushita Electric Corporation of America could cause harmful interference and would void the user's authority to operate this device.

To assure continued compliance, the shielded video cable with bonded ferrite cores provided as an optional accessory must be used when connecting this Wide Plasma Display to a computer device.(Part # TSX4515-3)

Also the ferrite core provided as a supplied accessory must be used when connecting this Wide Plasma Display to video equipment. (Refer to page 9, 14 and 17)

CANADIAN NOTICE:

This Class A digital apparatus complies with Canadian ICES-003.

AVIS CANADIEN:

Cet appareil numérique de la classe A est conforme à la norme NMB-003 du Canada.

IMPORTANT SAFETY NOTICE

WARNING: To prevent damage which may result in fire or shock hazard, do not expose this appliance to rain or moisture.

WARNING:

- 1) To prevent electric shock, do not remove cover. No user serviceable parts inside. Refer servicing to qualified service personnel.
- 2) Do not remove the grounding pin on the power plug. This apparatus is equipped with a three pin grounding-type power plug. This plug will only fit a grounding-type power outlet. This is a safety feature. If you are unable to insert the plug into the outlet, contact an electrician. Do not defeat the purpose of the grounding plug.

Safety Precautions

WARNING

Set up

Do not place the Wide Plasma Display on sloped or unstable surfaces.

- The Wide Plasma Display may fall off or tip over.

Do not place any objects on top of the Wide Plasma Display.

- If water is spilled onto the Wide Plasma Display or foreign objects get inside it, a short-circuit may occur which could result in fire or electric shock. If any foreign objects get inside the Wide Plasma Display, please consult an Authorized Service Center.

If using the pedestal (optional accessory), leave a space of 3 ¹⁵/₁₆" (10 cm) or more at the top, left and right, 2 ³/₈" (6 cm) or more at the bottom, and 2 ³/₄" (7 cm) or more at the rear. If using some other setting-up method, leave a space of 3 ¹⁵/₁₆" (10 cm) or more at the top, bottom, left and right, and ³/₄" (1.9 cm) or more at the rear.

When using the Wide Plasma Display

The Wide Plasma Display is designed to operate on 120 V AC, 50/60 Hz.

Do not cover the ventilation holes.

- Doing so may cause the Wide Plasma Display to overheat, which can cause fire or damage to the Wide Plasma Display.

Securely insert the power cord plug as far as it will go.

- If the plug is not fully inserted, heat may be generated which could cause fire. If the plug is damaged or the wall socket plate is loose, they should not be used.

Do not handle the power cord plug with wet hands.

- Doing so may cause electric shocks.

Do not do anything that might damage the power cable. When disconnecting the power cable, hold the plug, not the cable.

- Do not make any modifications, place heavy objects on, place near hot objects, heat, bend, twist or forcefully pull the power cable. Doing so may cause damages to the power cable which can cause fire or electric shock. If damages to the cable suspected, have it repaired at an Authorized Service Center.

If the Wide Plasma Display is not in use for a long period of time, unplug the power cord from wall outlet.

If problems occur during use

If a problem occurs (such as no picture or no sound), or if smoke or an abnormal odor detected from the Wide Plasma Display, Unplug the power cord immediately.

- Continuous use of the Display under these conditions might cause fire or permanent damage to the unit. Have the Display evaluated at an Authorized Service Center. Services to the Display by any unauthorized personnel are strongly discouraged due to its high voltage dangerous nature.

If water or foreign objects get inside the Wide Plasma Display, if the Wide Plasma Display is dropped, or if the cabinet becomes damaged, disconnect the power cord plug immediately.

- A short may occur, which could cause fire. Contact an Authorized Service Center for any repairs that need to be made.

Safety Precautions

CAUTION

This Wide Plasma Display is for use only with the following optional accessories. Use with any other type of optional accessories may cause instability which could result in the possibility of injury.

- | | | |
|--|---------------------------------|-------------|
| • Manufactured by Matsushita Electric Industrial Co., Ltd. | Pedestal | TY-ST42PT1U |
| • Manufactured by Matsushita Electric Industrial Co., Ltd. | Wall stand | TY-ST42PW1U |
| • Manufactured by Matsushita Electric Industrial Co., Ltd. | Mobile stand | TY-ST42PF1U |
| • Manufactured by Matsushita Electric Industrial Co., Ltd. | Wall-hanging bracket (vertical) | TY-WK42PV1U |
| • Manufactured by Matsushita Electric Industrial Co., Ltd. | Wall-hanging bracket (angled) | TY-WK42PR1U |
| • Manufactured by Matsushita Electric Industrial Co., Ltd. | Ceiling unit | TY-CE42PS1U |

Always be sure to ask a qualified technician to carry out set-up.

When using the Wide Plasma Display

Do not bring your hands, face or objects close to the ventilation holes of the Wide Plasma Display.

- Top of Wide Plasma Display is usually very hot due to high temperature exhaust air from ventilation holes. Burns or personal injuries can happen if any body parts brought too close. Placing any object near the top of the display could also result in heat damages to the object as well as to the Display due to its ventilation holes blocked.

Be sure to disconnect all cables before moving the Wide Plasma Display.

- Moving the Display with its cables attached might damage the cables which in turn can cause fire or electric shock.

Cleaning and maintenance

The front of the display panel has been specially treated. Wipe the panel surface gently using only a soft, lint-free cloth.

- If the surface is particularly dirty, wipe with a soft, lint-free cloth which has been soaked in water to which a small amount of neutral detergent has been added, and then wipe it evenly with a dry cloth of the same type until the surface is dry.
- Do not scratch or hit the surface of the panel with fingernails or other hard objects. Furthermore, avoid contact with volatile substances such as insect sprays, solvents and thinners, otherwise the quality of the surface may be adversely affected.

If the cabinet becomes dirty, wipe it with a soft, dry cloth.

- If the cabinet is particularly dirty, soak the cloth in water to which a small amount of neutral detergent has been added and then wring the cloth dry. Use this cloth to wipe the cabinet, and then wipe it dry with a dry cloth.
- Do not allow any detergent to come into direct contact with the surface of the Wide Plasma Display. If water droplets get inside the unit, operating problems may result.
- Avoid contact with volatile substances such as insect sprays, solvents and thinner, otherwise the quality of the cabinet surface may be adversely affected or the coating may peel off. Furthermore, do not leave it for long periods in contact with articles made from rubber or PVC.

Disconnect the power plug from the wall outlet as a safety precaution before carrying out any cleaning.

- Electric shocks can result if this is not done.

Clean the power cable regularly to prevent it becoming dusty.

- Built-up dust on power cord plug can increase humidity which might damage the insulation and cause fire. Unplug the cord from wall outlet and clean it with a dry cloth.

Note:

If still pictures from sources such as video games or computers are projected for long periods, the image may become burned into the Wide Plasma Display panel (producing an "afterimage").

Accessories

Accessories Supplied

Check that you have the accessories and items shown 

Operating Instruction book

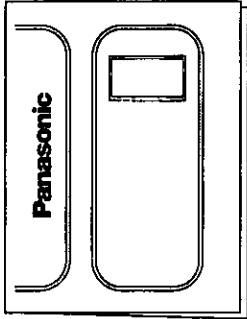

Remote Control Transmitter
TNQE177

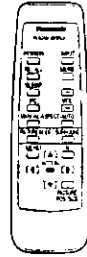

Batteries for the Remote Control
Transmitter
(R6 (AA) Battery x 2)

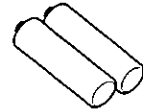

Ferrite core
TSK1027

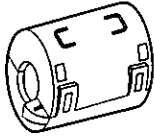

Warranty



Optional Accessories

- Speakers
TY-SP42P1U (For PT-42P1)
TY-SP37P1U (For PT-37P1)

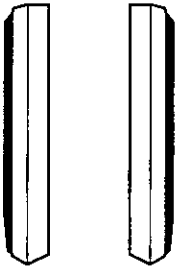

- Pedestal
TY-ST42PT1U



- Wall stand
TY-ST42PW1U

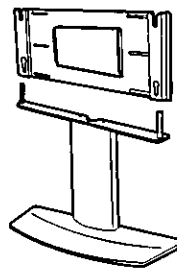

- Mobile stand
TY-ST42PF1U
(For PT-42P1 Only)

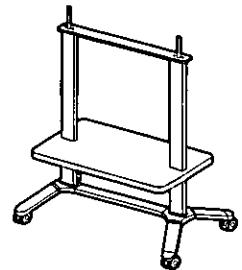

- Wall-hanging bracket
(vertical)
TY-WK42PV1U

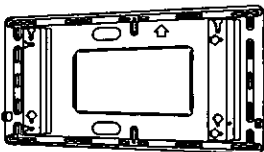

- Wall-hanging bracket
(angled)
TY-WK42PR1U

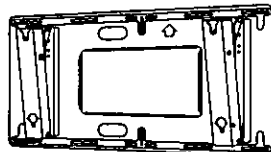

- Ceiling unit
TY-CE42PS1U

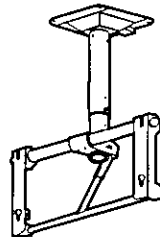

- RS-232C
Conversion cable
TY-SCP02RS1U



- PC cable
TSX4515-3



Remote Control Batteries

1

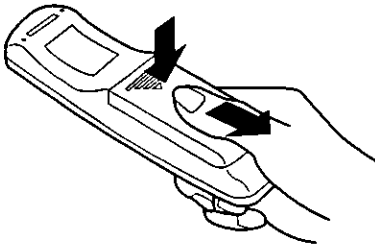

Press and slide off the battery cover

2

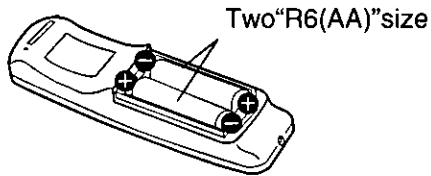

Insert batteries – note correct polarity (+ and –)

3

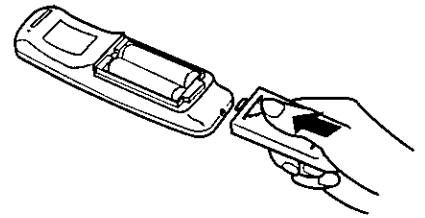

Replace the cover

Note:

- (1) Make sure that the batteries are fitted properly.
- (2) Do not mix old batteries with new batteries. Remove old, exhausted batteries immediately.
- (3) Do not mix different battery types, i.e. Alkaline and Manganese. Do not use rechargeable (Ni-Cad) batteries.

Quick Start Guide

Connections

Connect the speakers.

When connecting the speakers, be sure to use only the optional accessory speakers. Refer to the speakers Installation Manual for details on speaker installation. Fit the speakers and connect the speakers.

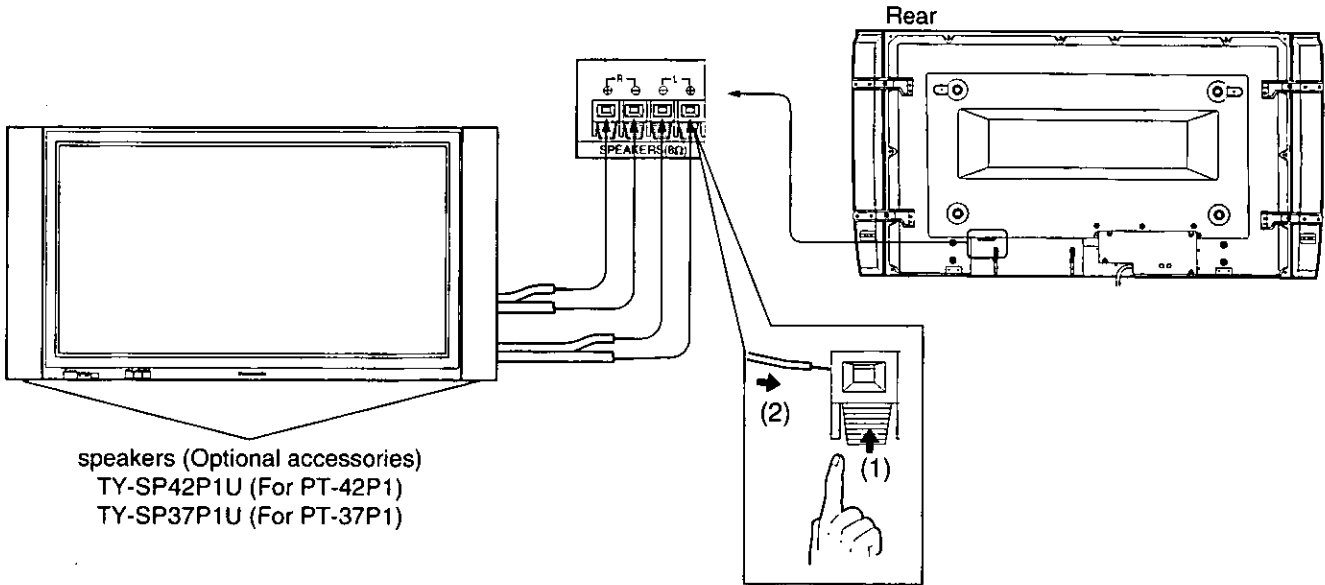

Connect equipment such as a VCR.

Connect the signal source equipment see pages 14 to 18.

(Example) When connecting an S-VIDEO VCR.

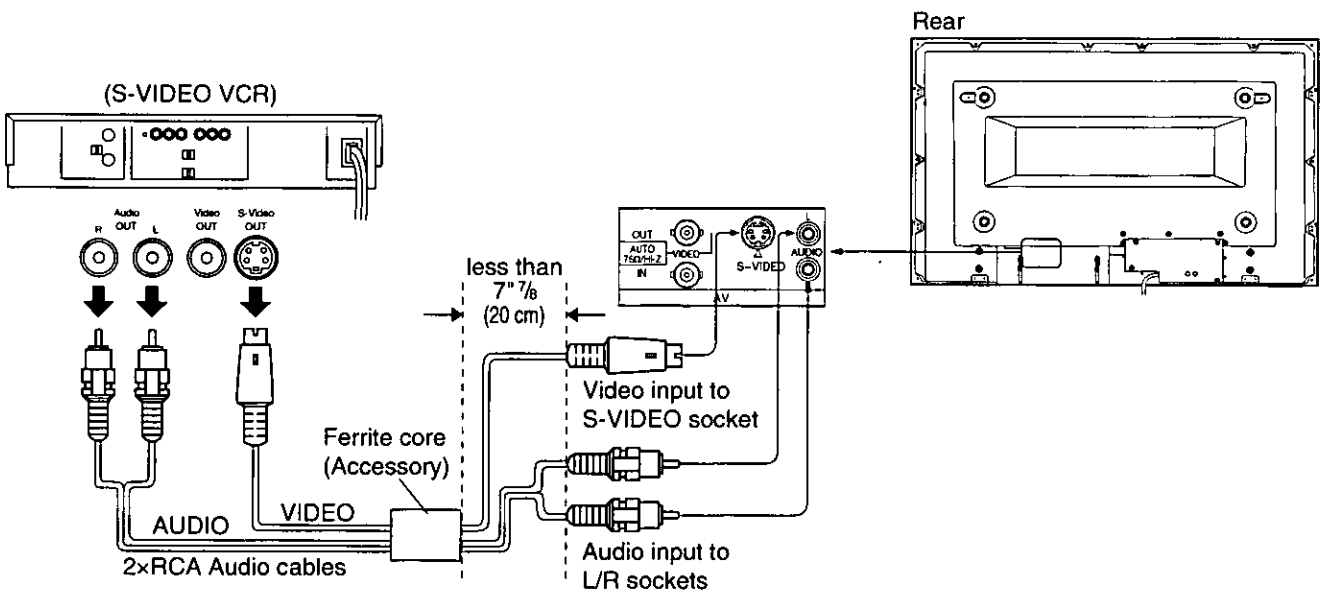

Quick Start Guide

Connect the Plug to the Wall Outlet

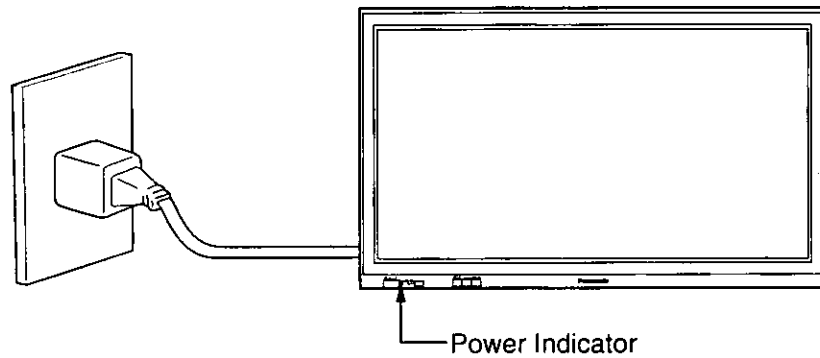

How to Turn the Power On

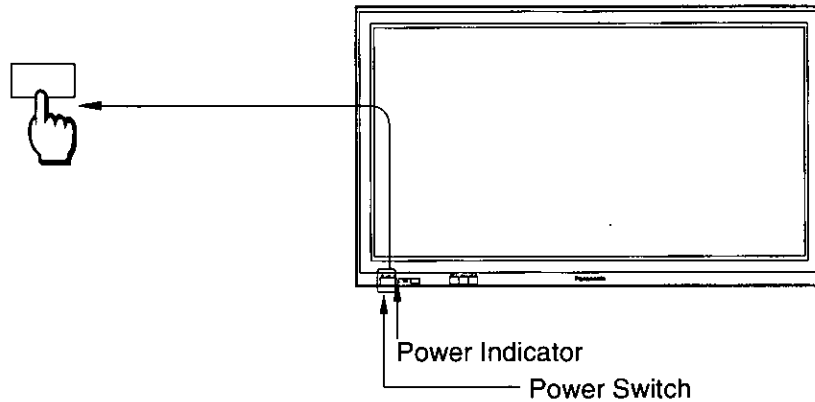

Push the Power switch on the Wide Plasma Display to turn the set on.

The Power Indicator will light.
Power-OFF..... Indicator not illuminated
Stand-by..... Red
Power-ON Green

Quick Start Guide

Select the input signal

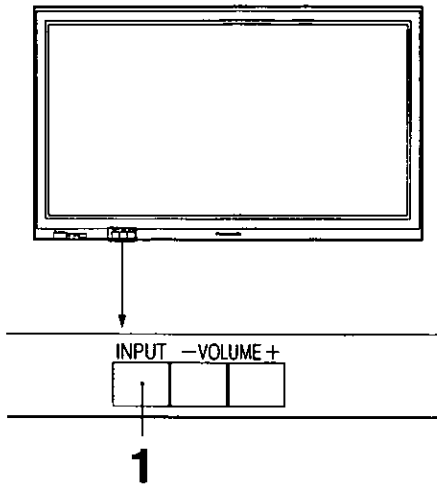

1



Press the INPUT button to select the input video signal to be played back from the equipment such as a VCR which has been connected to the Wide Plasma Display.

Basic Controls

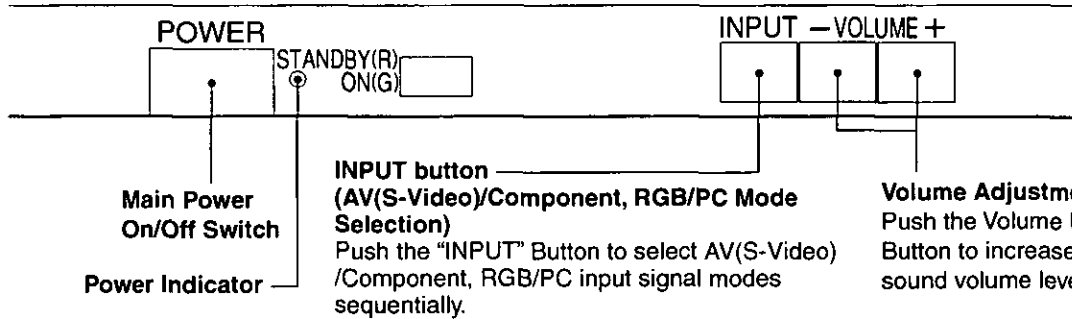

Recall Button
Push the "Recall" Button to display the current system status.

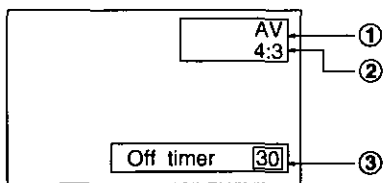

- ① AV(S-Video)/Component, RGB/PC Mode
 - ② Aspect Mode (See page 20)
 - ③ Off timer
- The off timer indicator is displayed only when the off timer has been set.

SLEEP (Off Timer) Button
The Wide Plasma Display may be preset to switch to stand-by after a fixed period.
The setting changes to 30 minutes, 60 minutes, 90 minutes and 0 minutes (off timer cancelled) each time the button is pressed.

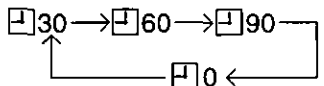

When three minutes remain, "Off timer 3" will flash.
The off timer is cancelled if there is a power outage.

PC Mode Selection
Push the "PC" mode selection button to select the PC mode.
This button is used to switch directly to PC mode.

ASPECT-MANUAL button
(see page 20)

PICTURE MODE button
(see page 25)

MENU button

Stand-by (ON/OFF) button

The Wide Plasma Display must first be switched on at the wall outlet and at the Power Switch. (See page 10)
Push this button to turn the Wide Plasma Display ON, from STANDBY mode.
Push it again to turn the Wide Plasma Display to STANDBY mode.

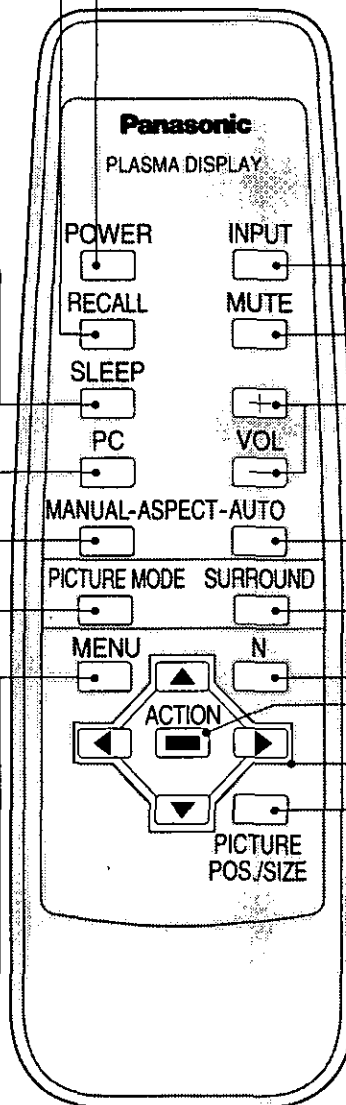

INPUT button (AV(S-Video)/Component, RGB/PC Mode Selection)
Push the "INPUT" Button to select AV(S-Video)/Component, RGB/PC input signal modes sequentially.

Sound mute On/Off

Volume Adjustment
Push the Volume Up "+" or Down "-" Button to increase or decrease the sound volume level.

ASPECT-AUTO button
(see page 20)

Surround button
(see page 24)

Normalization button
(see page 23,26,27,28)

ACTION button

Cursor buttons to make selections and adjustments

PICTURE POS./SIZE button
(see page 22)

Connections

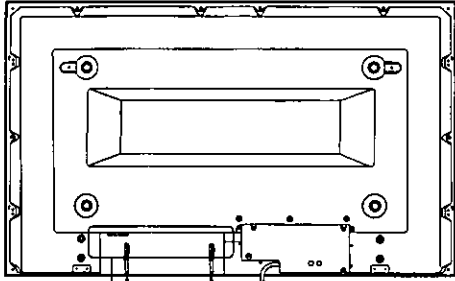

Cable fixing bands

Secure any excess cables with bands as required.

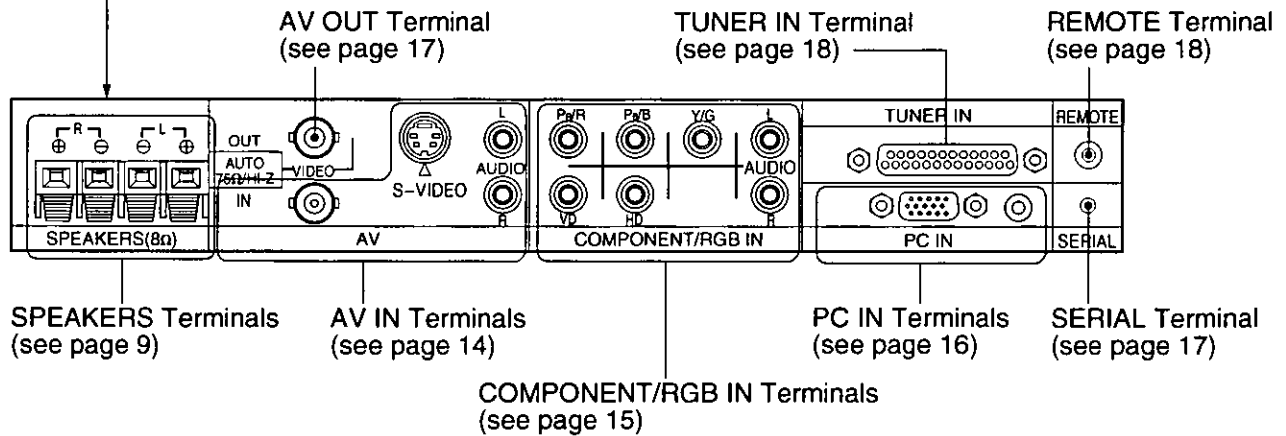
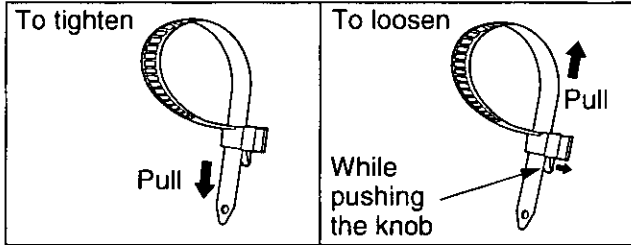

Connections

How to connect the AV Input Terminals

S-VIDEO Signal Connection

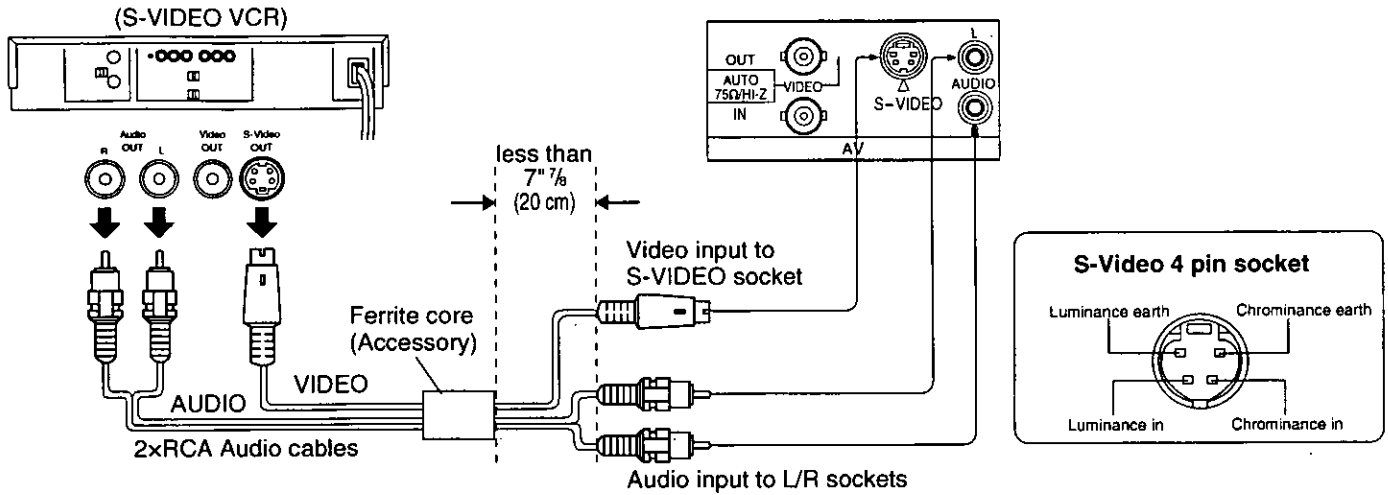

Video Signal Connection

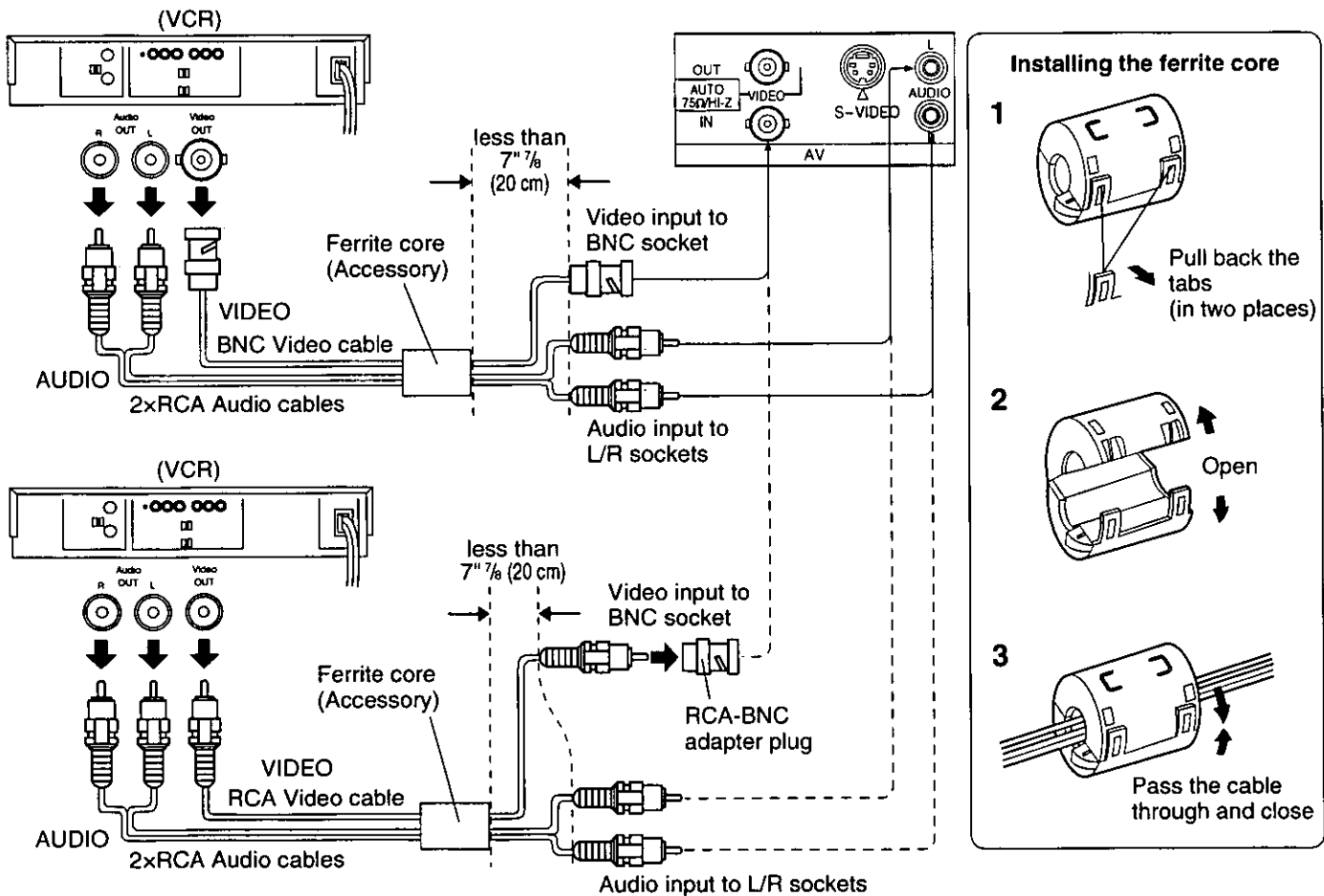

Note:

- (1) Additional equipment and cables shown are not supplied with this set.
- (2) When connecting video cables, priority is given to the S-Video cable when the S-Video input terminal and the video input terminal are connected at the same time.

Connections

How to connect the COMPONENT/RGB Input Terminals

Component signals (Y, P_B, P_R) Connection

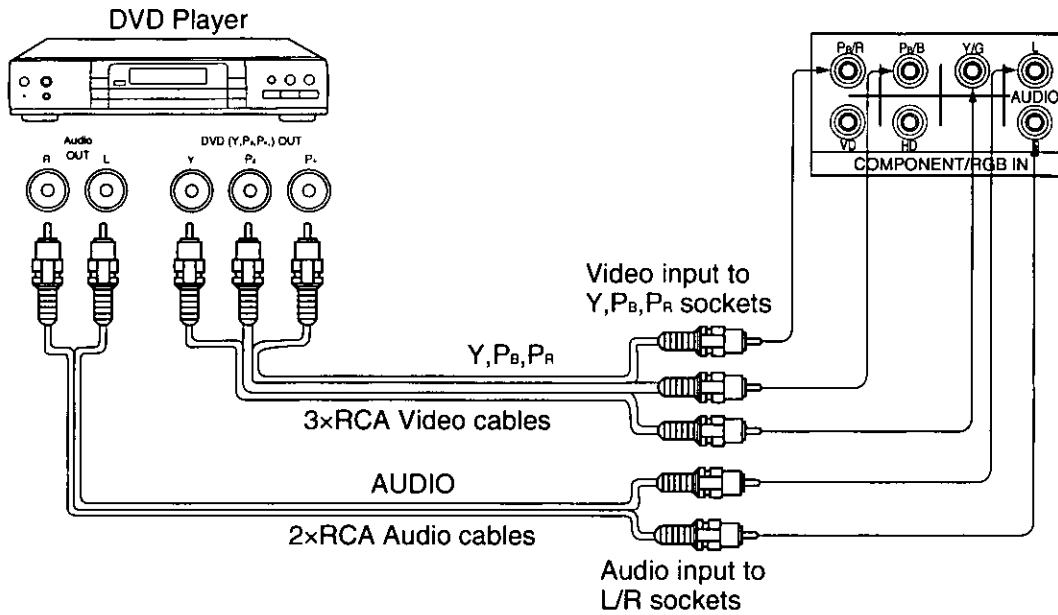

Note:

- (1) Change the "COMPONENT/RGB IN" setting in the "Set up" menu to "Y/PB/PR". (Refer to page 31.)
- (2) Additional equipment and cables shown are not supplied with this set.

RGB signals (R, G, B, HD, VD) Connection

Example of input signal source

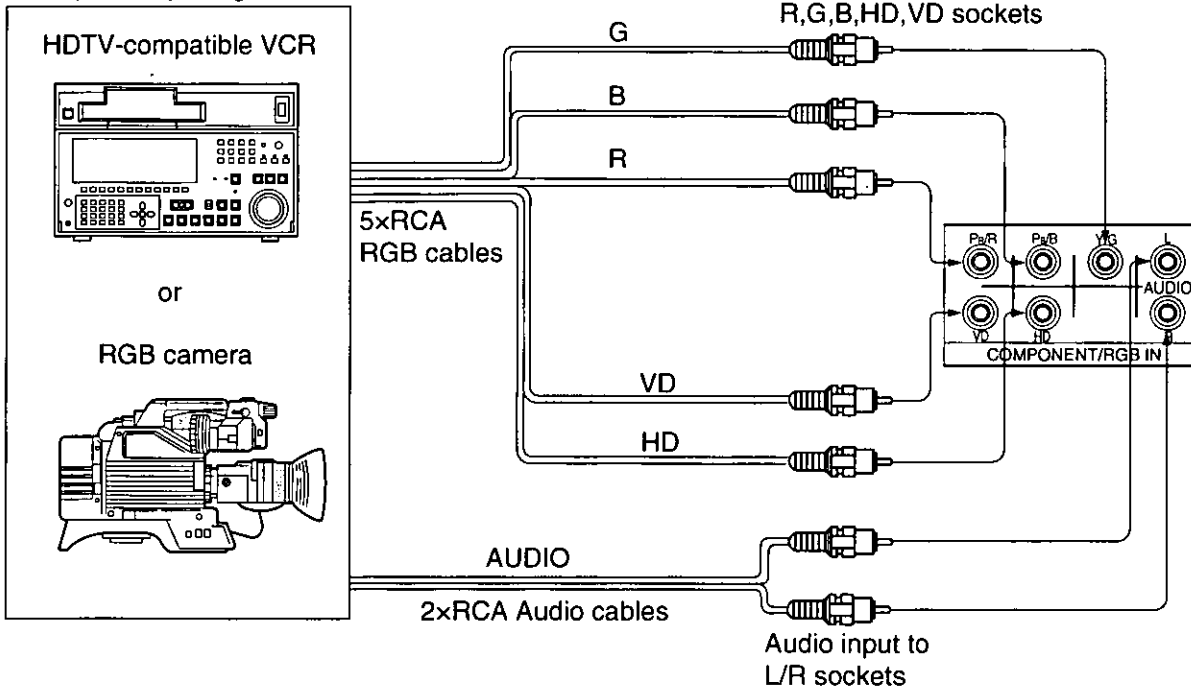

Note:

- (1) Change the "COMPONENT/RGB IN" setting in the "Set up" menu to "RGB". (Refer to page 31.)
- (2) Additional equipment and cables shown are not supplied with this set.

Connections

How to connect the PC Input Terminals

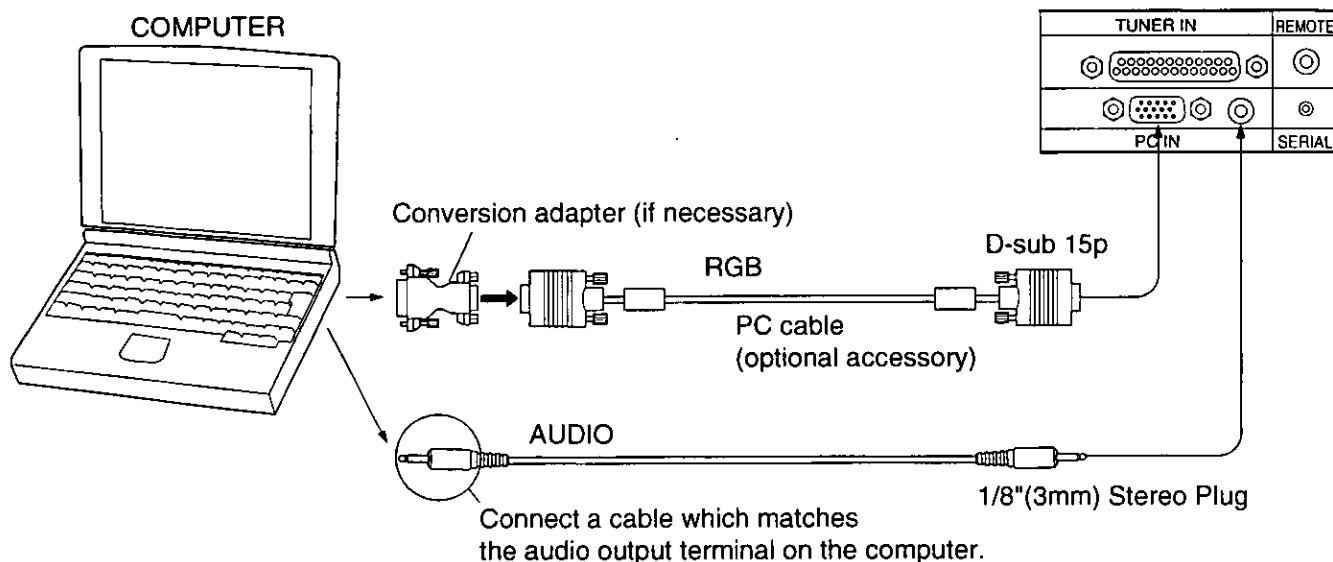

Note:

- (1) Computer signals which can be input are those with a horizontal scanning frequency of 15.6 to 50 kHz and a vertical scanning frequency of 50 to 75 Hz. (However, signals cannot be displayed if they have a horizontal scanning frequency of less than 30 kHz and a vertical scanning frequency of more than 65 Hz, or a horizontal scanning frequency of more than 40 kHz and a vertical scanning frequency of less than 55 Hz.)
- (2) The display resolution is a maximum 640 × 480 dots when the aspect mode is set to "4:3", and 852 × 480 dots when the aspect mode is set to "16:9". If the display resolution exceeds these maximums, it may not be possible to show fine detail with sufficient clarity.
- (3) The PC input terminals are DDC1/2B-compatible. If the computer being connected is not DDC1/2B-compatible, you will need to make setting changes at the computer at the time of connection.
- (4) Some PC models cannot be connected to the set.
- (5) An adapter is required to use the PC cable (D-sub 15P) to connect a PC-98 series computer (which has a D-sub 15P terminal) or a Macintosh computer to the set.
- (6) There is no need to use an adapter for computers with DOS/V compatible D-sub 15P terminal.
- (7) The computer shown in the illustration is for example purposes only.
- (8) Additional equipment and cables shown are not supplied with this set.
- (9) The picture will become dark if a PC signal with a vertical scanning frequency of over 62 Hz is input. To obtain the optimum picture quality with the Wide Plasma Display, a vertical scanning frequency of 60 Hz is recommended.
- (10) Do not set the horizontal and vertical scanning frequencies for PC signals which are above or below the specified frequency range.

Signal Names for D-sub 15P Connector

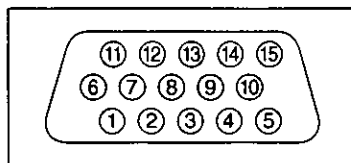

Pin Layout for PC Input Terminal

Pin No.	Signal Name	Pin No.	Signal Name	Pin No.	Signal Name
①	R	⑥	GND (Ground)	⑪	GND (Ground)
②	G	⑦	GND (Ground)	⑫	SDA
③	B	⑧	GND (Ground)	⑬	HD/SYNC
④	GND (Ground)	⑨	NC (not connected)	⑭	VD
⑤	GND (Ground)	⑩	GND (Ground)	⑮	SCL

Connections

How to connect the AV Output Terminal to other equipment

The video output terminal outputs the signals which are input to the video input terminal.

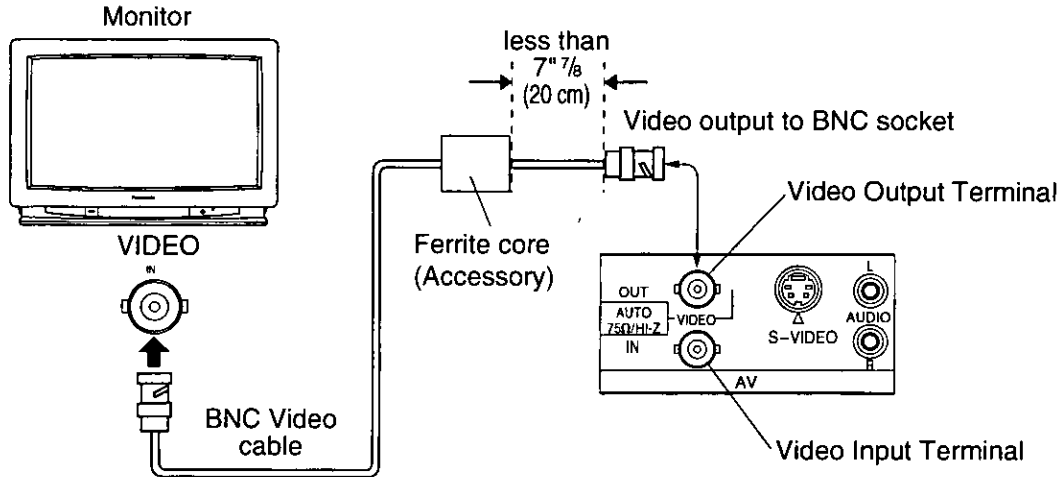

Note:

- (1) The video output terminal can only output the identical signal to that which is input to the video input terminal.
- (2) Additional equipment and cables shown are not supplied with this set.

How to connect the SERIAL Terminal

The SERIAL terminal is used when the Wide Plasma Display is controlled by a computer.

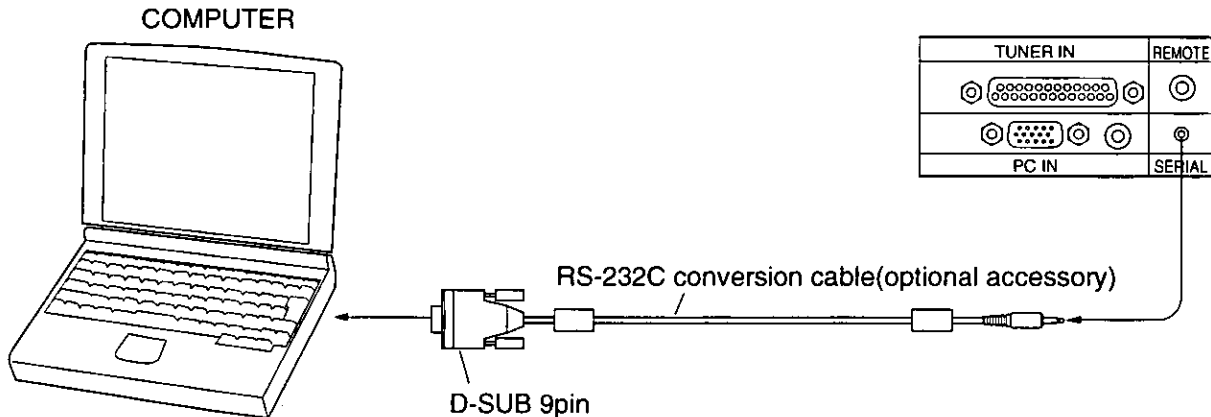

Note:

- (1) Use the TY-SCP02RS1U RS-232C conversion cable (optional accessory) to connect the computer to the Wide Plasma Display.
- (2) Refer to page 32 for details of the control method for the Wide Plasma Display.
- (3) The computer shown is for example purposes only.
- (4) Additional equipment and cables shown are not supplied with this set.

Connections

How to connect the REMOTE Terminal

The REMOTE terminal is reserved for use with future compatible components.

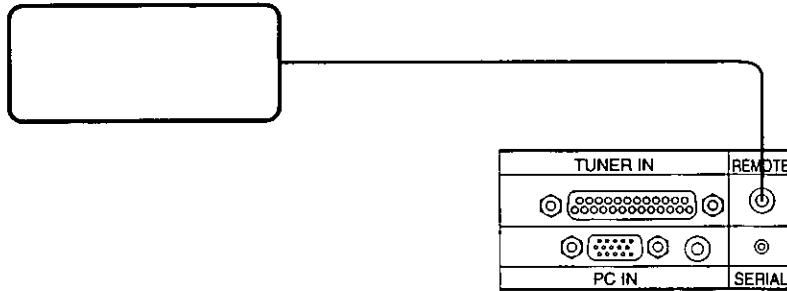

How to connect the TUNER Input Terminal



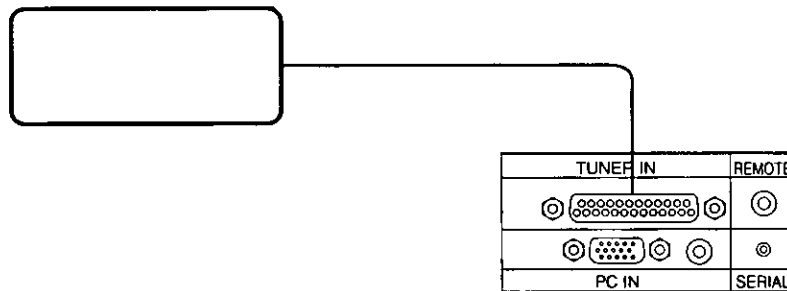





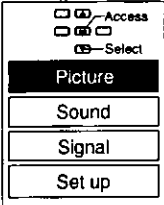

The TUNER Input terminal is reserved for use with future external compatible components.

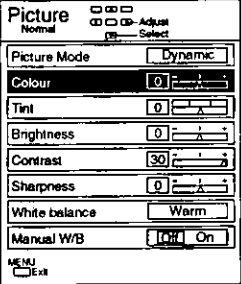

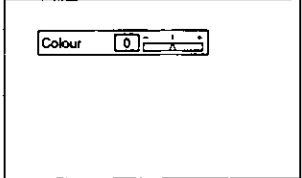
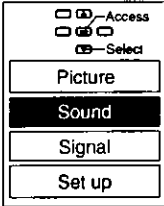
Flowchart of Menu

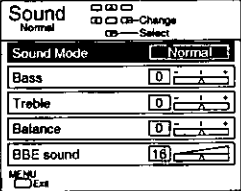
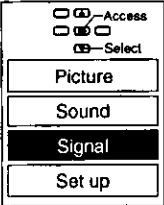
If the MENU button is pressed, the Menu screen will be displayed.

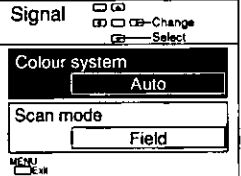
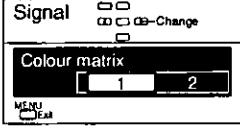
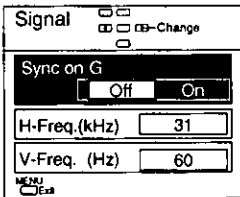
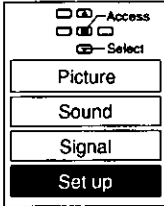
If the MENU button is pressed once more while the menu screen is displayed, the Menu screen will be cleared.

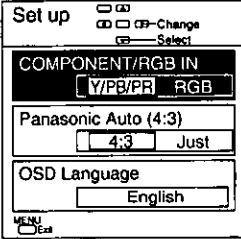
Menu	On-Screen Indication	
<p>Picture</p> <p>(Refer to page 26.)</p>	<p>ACTION</p>  <p>↓</p> 	<p>Picture</p>  <p>adjust</p>  
<p>Sound</p> <p>(Refer to page 28.)</p>	<p>ACTION</p>  <p>↓</p> 	<p>Sound</p> 
<p>Signal</p> <p>(Refer to page 29.)</p>	<p>ACTION</p>  <p>↓</p> 	<p>Signal</p>  <p>During AV(S-Video) mode</p>  <p>During component mode</p>  <p>During RGB and PC modes</p>
<p>Set up</p> <p>(Refer to page 31.)</p>	<p>ACTION</p>  <p>→</p> 	<p>Set up</p> 

ASPECT Controls

The Wide Plasma Display will allow you to enjoy viewing the picture at its maximum size, including wide screen "cinema format" picture.



ASPECT-AUTO Button (Panasonic Auto)
Press the ASPECT-AUTO button to switch to Panasonic Auto mode. The display will automatically become enlarged.

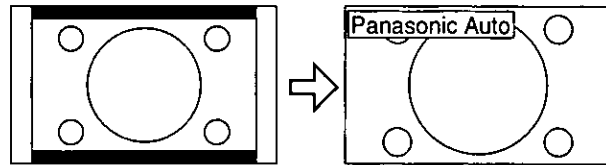

For an elongated image

Image is expanded

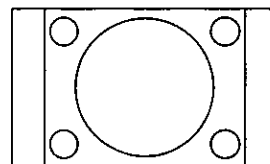

For a 4:3 image

Changes in accordance with the Panasonic Auto mode setting. (Refer to page 31.)

Note:

- (1) If a 525p or 1080i signal is input during Component input signal mode and during RGB and PC input signal mode the controls will not operate.

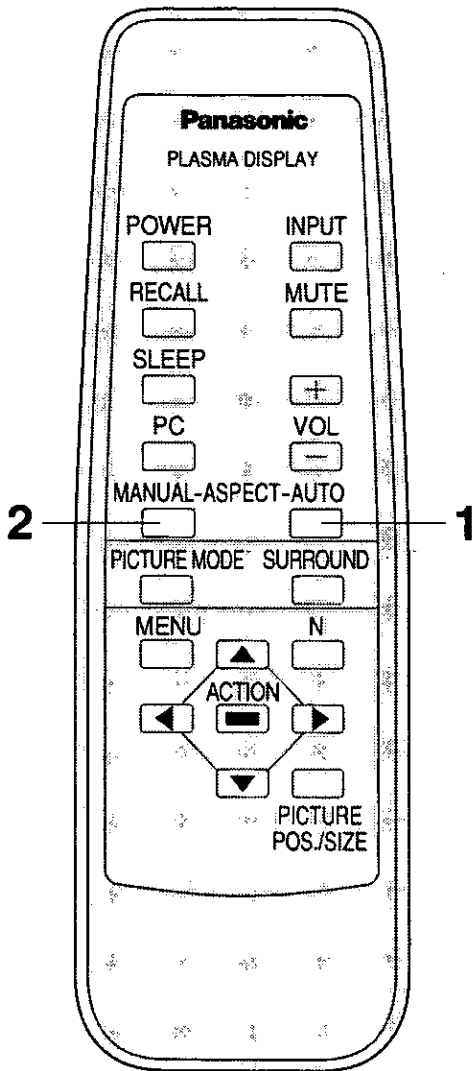

ASPECT-MANUAL button
The aspect mode changes each time the ASPECT-MANUAL button is pressed.

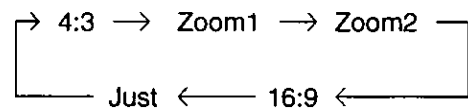

Note:

- (1) During RGB and PC input signal mode, the mode switches between "4:3" and "16:9" only.
- (2) For a 525p (480p) signal input during "Component" input signal mode, the mode switches between "Zoom1" and "16:9" only.
- (3) When a 1080i signal is being received, the mode is set to "16:9" mode, and switching is not possible.
- (4) The aspect mode is memorised separately for different input signal formats (NTSC/PAL/SECAM, 525p, RGB and PC). (525p includes 525i and 625i signals.)

ASPECT Controls

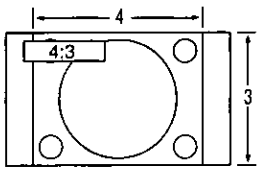
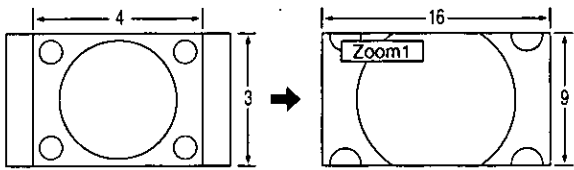
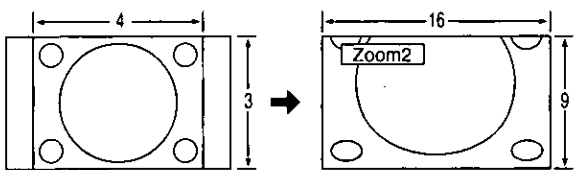
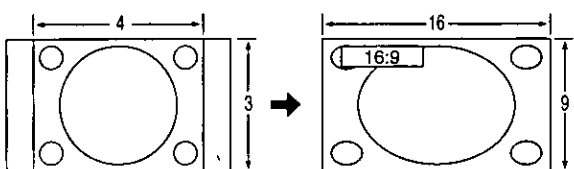
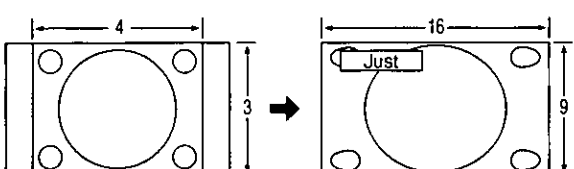
Mode	Picture	Explanation
4:3		<p>4:3 will display a 4:3 picture at its standard 4:3 size and can be selected if you wish to view in this format.</p>
Zoom1		<p>Zoom1 mode magnifies the central section of the picture.</p>
Zoom2		<p>Zoom2 mode compresses the bottom section of the screen which is cut in Zoom1 mode, so that this section still remains visible.</p>
16:9		<p>16:9 will display the picture at its maximum size but with slight elongation.</p>
Just		<p>Just mode will display a 4:3 picture at maximum size but with aspect correction applied to the centre of the screen so that elongation is only apparent at the left and right edges of the screen. The size of the picture will depend on the original signal.</p>

Note:

- (1) The S-Video terminal on this set can detect specially encoded signals that are compatible with wide screen monitors. When a full image from the S-Video terminal of specially encoded video is detected by the set, the screen size automatically sets to "16:9" mode.

PICTURE POS./SIZE Controls

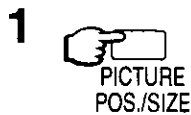

PICTURE POS./SIZE button

When the PICTURE POS./SIZE button is pressed, the Picture Pos./Size menu appears, and the picture size and vertical picture position can then be adjusted.

The adjustable items and adjustment ranges vary for each input signal and aspect mode.

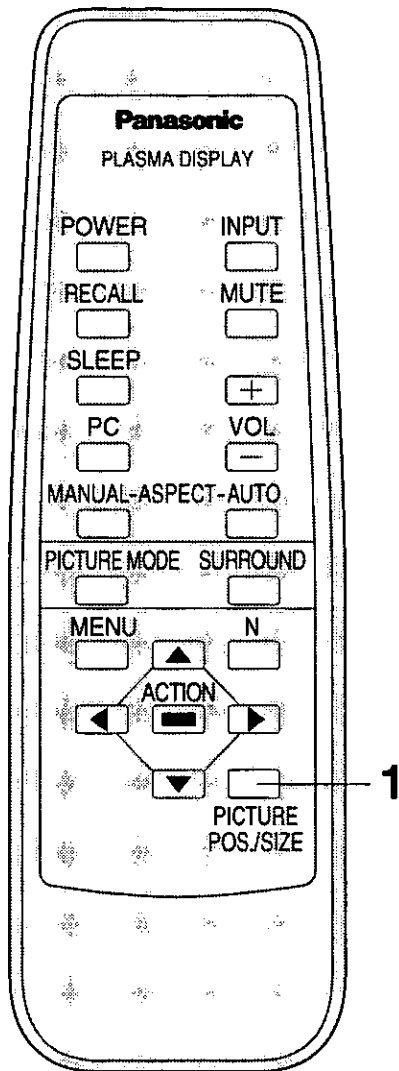



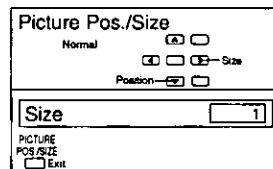

During "AV(S-Video)" and "Component" input signal modes

The Position Left "◀" and Right "▶" buttons can be used to change the picture size.

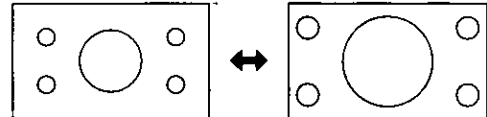

The Position Up "▲" and Down "▼" buttons can be used to adjust the vertical picture position.

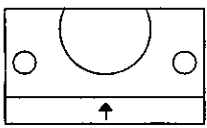

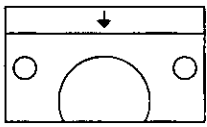
Button	Picture
Changing the size 	Example 
Moving the picture position (up) 	
Moving the picture position (down) 	

Note:

- (1) The picture size cannot be changed in "Zoom1" mode when a 525p (480p) component signal is being input.
- (2) The vertical position cannot be changed when Size 1 and Size 2 have been selected in "4:3" mode and when Size 1 has been selected in "16:9" mode. In addition, the vertical position cannot be changed when 1080i signals are being input.
- (3) Adjustment details are memorised separately for different input signal formats (NTSC/PAL/SECAM, 525p (480p), 1080i, 525i and 625i).
- (4) If a "Cue" or "Rew" signal from a VCR or DVD player is received, the picture position will shift up or down. This picture position movement cannot be controlled by the Picture Pos./Size function.

PICTURE POS./SIZE Controls

During "RGB" and "PC" input signal modes

Choose the option and adjust by pushing the Position Up "▲" or Down "▼" buttons, and by setting with the Position Left "◀" or Right "▶" buttons.

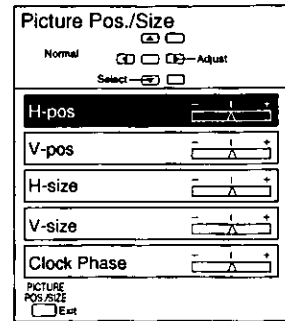
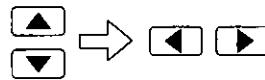

Mode	Picture	
H-pos	When the Position Left "◀" button is pressed 	When the Position Right "▶" button is pressed
	When the Position Left "◀" button is pressed 	When the Position Right "▶" button is pressed
V-pos	When the Position Left "◀" button is pressed 	When the Position Right "▶" button is pressed
	When the Position Left "◀" button is pressed 	When the Position Right "▶" button is pressed
H-size	When the Position Left "◀" button is pressed 	When the Position Right "▶" button is pressed
	When the Position Left "◀" button is pressed 	When the Position Right "▶" button is pressed
V-size	When the Position Left "◀" button is pressed 	When the Position Right "▶" button is pressed
	When the Position Left "◀" button is pressed 	When the Position Right "▶" button is pressed
Clock Phase	Flickering and distortion can be eliminated by using the Position Left "◀" or Right "▶" button to carry out adjustment.	

Note:

- (1) The same adjustment details are memorized in both RGB and PC input signal modes for each type of input signal (frequency).

Helpful Hint (Normalization)

If the N button on the remote control unit is pressed when the Picture Pos./Size display is active, all adjustment values will be returned to the factory setting level.

SURROUND Controls

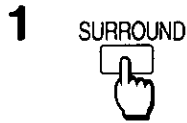

Surround Button

The benefits of surround sound are enormous. You can be completely enveloped in sound; just as if you were at a concert hall or cinema.

The surround setting switches on and off each time the SURROUND button is pressed.

On ← → Off

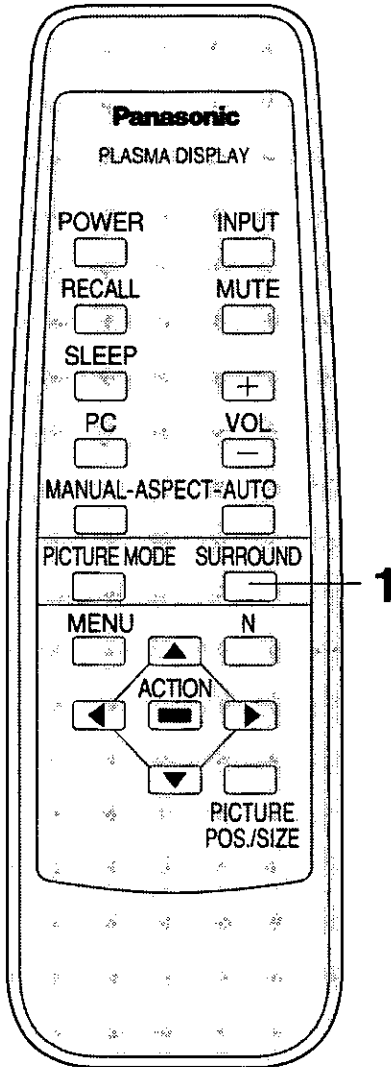
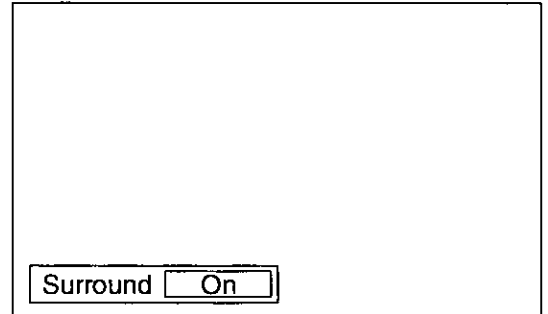

Note:

(1) The surround settings are memorized separately for each input terminal (AV, COMPONENT/RGB and PC).

PICTURE MODE Controls

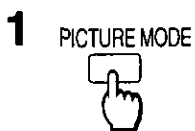

PICTURE MODE Button

Operation switches between "Normal" and "Dynamic" each time the PICTURE MODE button is pressed.

Normal \longleftrightarrow Dynamic

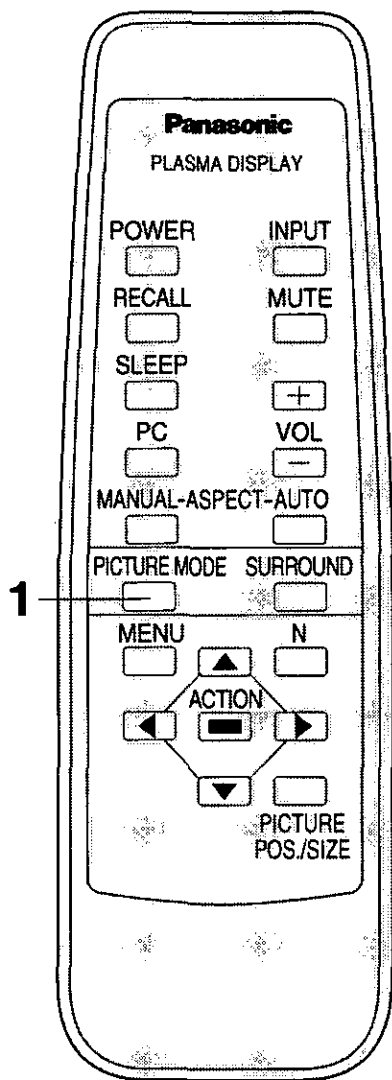
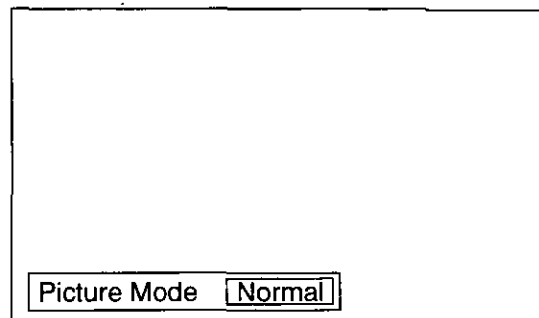

Normal	For viewing in normal (evening lighting) environments. This menu selects normal levels of Brightness and Contrast.
Dynamic	For viewing in brighter environments. This menu selects a higher than normal levels of Brightness and Contrast.

Note:

- (1) If you would like to change the picture and color of the selected Picture Mode to something else, adjust using the "Picture" menu command in the Menu. (Refer to page 26.)
- (2) The setting details are memorized separately for five types of input signal format (NTSC, PAL, SECAM, 1080i and RGB/PC). (NTSC includes 525i and 525p (480p) signals, and PAL includes 625i signals.)

Picture Menu

1. Push the "Menu" Button.

2. Select the "Picture" Menu by pushing the Position Up "▲" or Down "▼" Button and Access the "Picture" Menu by pushing the "ACTION" Button.

3. Select the required function by pushing the Position Up "▲" or Down "▼" buttons, and access and alter the setting by pushing the Position Left "◀" or Right "▶" buttons.

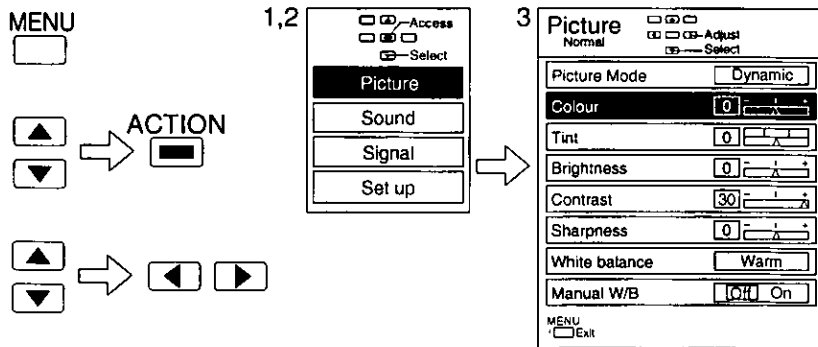

Note:

- (1) You can change the level of each Function (Picture Mode, Colour, Tint, Brightness, Contrast, Sharpness, White balance) for each picture Menu.
- (2) The setting details for normal and dynamic respectively are memorized separately for five types of input signal format (NTSC, PAL, SECAM, 1080i and RGB/PC). (NTSC includes 525i and 525p (480p) signals, and PAL includes 625i signals.)

Picture Mode	Function
Normal	For viewing in normal (evening lighting) environments. This menu selects the normal levels of Brightness and Contrast.
Dynamic	For viewing in brighter environments. This menu selects a higher than normal levels of Brightness and Contrast.

Note:

- (1) The "Tint" setting can be adjusted for NTSC signal only.
- (2) "Colour", "Tint" and "Sharpness" settings cannot be adjusted during "RGB" and "PC" input signal modes.
- (3) If the "Manual W/B" setting is changed to ON and the Position Down "▼" button is pressed, the "Manual W/B" menu will be displayed. (Refer to page 27.)
- (4) The adjustment range values should be used as an adjustment reference.

Item	Effect	Adjustment range
Picture Mode	◀ ▶	Normal / Dynamic
Colour	◀ ▶ Less More	-30 30
Tint (NTSC only)	◀ ▶ Reddish Greenish	-30 30
Brightness	◀ ▶ Darker Brighter	-15 15
Contrast	◀ ▶ Less More	-30 30
Sharpness	◀ ▶ Less More	-15 15
White balance	◀ ▶	Warm / Normal / Cool
Manual W/B	◀ ▶	Off / On

Helpful Hint (Normalization)

If the N button on the remote control unit is pressed when the "Picture" menu is displayed, all adjustment values will be returned to the factory setting level of each picture mode.

Picture Menu

1. Use the Position Up “▲” or Down “▼” buttons to select the “Manual W/B” menu from the “Picture” menu, and then use the Position Right “▶” button to select “On”.

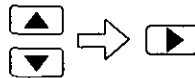

2. Press the Position Down “▼” button. (The “Manual W/B” menu screen will then be displayed.)



3. Select the required function by pushing the Position Up “▲” or Down “▼” buttons, and access and alter the setting by pushing the Position Left “◀” or Right “▶” buttons.

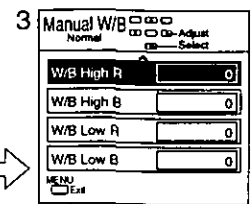
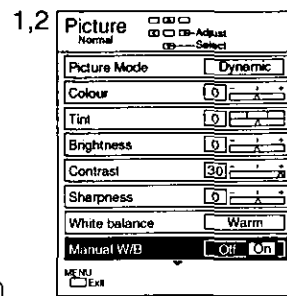
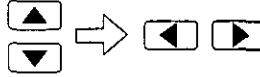

Item	Effect	Adjustment range	Details
W/B High R	◀ ▶ Less More	-30 – 30	Adjusts the white balance for light red areas.
W/B High B	◀ ▶ Less More	-30 – 30	Adjusts the white balance for light blue areas.
W/B Low R	◀ ▶ Less More	-30 – 30	Adjusts the white balance for dark red areas.
W/B Low B	◀ ▶ Less More	-30 – 30	Adjusts the white balance for dark blue areas.

Note:

(1) Carry out “W/B” adjustment as follows.

- ① Adjust the white balance of the bright sections using the “W/B High R” and “W/B High B” settings.
- ② Adjust the white balance of the dark sections using the “W/B Low R” and “W/B Low B” settings.
- ③ Repeat steps ① and ② to adjust.

Steps ① and ② affect each other’s settings, so repeat each step in turn to make the adjustment.

- (2) The adjusted values are memorized separately for each Picture Mode (Normal/Dynamic).
- (3) The adjustment range values should be used as an adjustment reference.

Helpful Hint (Normalization)

If the N button on the remote control unit is pressed when the “Manual W/B” menu is displayed, all adjustment values will be returned to the factory setting level.

Sound Menu

1. Push the "Menu" Button.



2. Select the "Sound" Menu by pushing the Position Up "▲" or Down "▼" Button and Access the "Sound" Menu by pushing the "ACTION" Button.

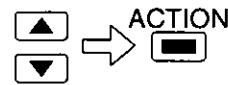

3. Select the required function by pushing the Position Up "▲" or Down "▼" buttons, and access and alter the setting by pushing the Position Left "◀" or Right "▶" buttons.

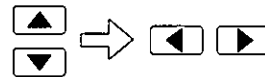

1,2

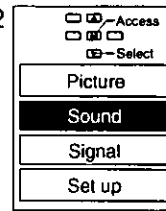

3

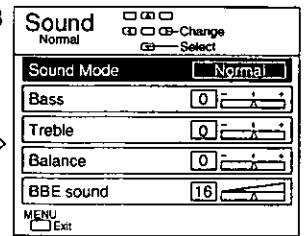

Note:

- (1) You can change the level of each Function (Bass, Treble, Balance, BBE sound) for each Sound Menu.
- (2) The same adjustment details are memorized for all input terminals (AV(S-Video), COMPONENT/RGB and PC).

Sound Mode	Function
Normal	Same sound as the input signal
Music	Bass and Treble is set to optimum level for music.
Speech	Bass and Treble is set to optimum level for speech.

Note:

- (1) "BBE sound" adjusts the clarity of the sound. An adjustment value of "0" is for normal sound.
- (2) Adjustment values other than the "Balance" value are memorized separately for each Sound Mode (Normal/Music/Speech).
- (3) The adjustment range values should be used as an adjustment reference.

Item	Effect	Adjustment range
Bass	◀ Less ▶ More	-15 +15
Treble	◀ Less ▶ More	-15 +15
Balance	◀ Left SP. ▶ Right SP.	-30 +30
BBE sound	◀ Less ▶ More	0 30

Helpful Hint (Normalization)

If the N button on the remote control unit is pressed when the "Sound" menu is displayed, all adjustment values will be returned to the factory setting level of each sound mode.

Signal Menu

1. Push the "Menu" Button.



2. Select the "Signal" Menu by pushing the Position Up "▲" or Down "▼" Button and Access the "Signal" Menu by pushing the "ACTION" Button.

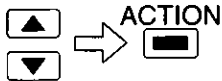

3. Select the required mode by pushing the Position Up "▲" or Down "▼" buttons, and set the appropriate function by the Position Left "◀" or Right "▶" buttons.

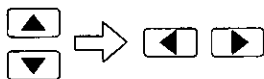

1,2

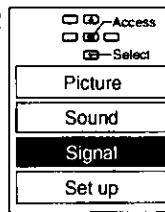

3

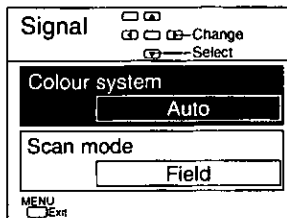

During "AV(S-Video)" input signal mode

Note:

(1) The "Signal" screen changes depending on the input signal mode (AV(S-Video), Component, RGB or PC).

During "AV(S-Video)" input signal mode

Select the mode ▲ ▼

Select the function ◀ ▶

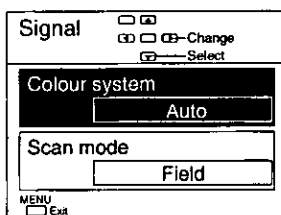

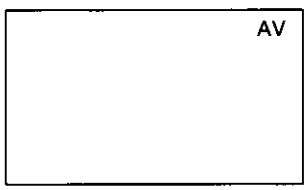
Mode	Function
Colour system	<p>Set the color system to match the input signal. If set to "Auto", the color system is determined automatically.</p> <p>→Auto←→NTSC← →SECAM←→PAL←</p> <p>Note: (1)The display color for the input signal mode ("AV") changes according to the color system setting.</p> <p>Auto - Green NTSC - Magenta PAL - Yellow SECAM - Cyan</p> 
Scan mode	<p>→Field← →Frame←</p> <p>If watching a normal image, select the "Field". If the recording mode used for a device such as a digital video camera is "Frame", select the "Frame" to obtain a higher-quality playback image.</p>

During "Component" input signal mode

Select ◀ ▶

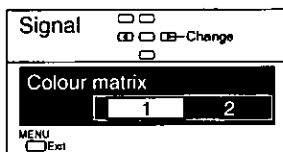

Mode	Function
Colour matrix	<p>If the output signals from the source connected to the COMPONENT/RGB input terminals are in 525p (480p) format, the colors in the images from this source will be set to their natural colors.</p>

Signal Menu

During "RGB" and "PC" input signal modes

Select

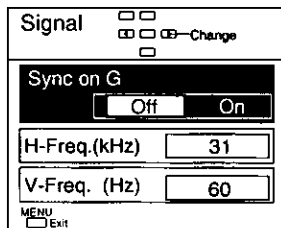

Mode	Function
Sync on G	Set to "On" when the input signals from the sources connected to the COMPONENT/RGB (R, G, B, HD and VD) input terminals and the PC input terminal are "Sync on G" signals.
H-Freq.(kHz)	Shows the horizontal scanning frequency for the video signals which are currently being displayed (display only).
V-Freq.(Hz)	Shows the vertical scanning frequency for the video signals which are currently being displayed (display only).

Note:

(1) The "Sync on G" setting is applied to both the COMPONENT/RGB and PC input terminals.

Set up Menu

1. Push the "Menu" Button.



2. Select the "Set up" Menu by pushing the Position Up "▲" or Down "▼" Button and Access the "Set up" Menu by pushing the "ACTION" Button.

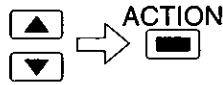

3. Select the required mode by pushing the Position Up "▲" or Down "▼" buttons, and set appropriate function by pushing the Position Left "◀" or Right "▶" buttons.

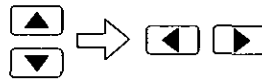

1,2

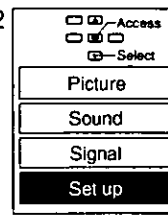

3

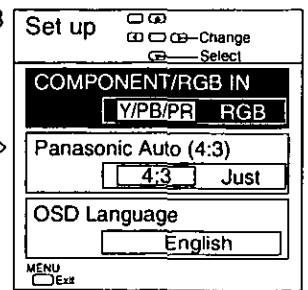

Mode	Function
COMPONENT/ RGB IN	Select to match the signals from the source connected to the COMPONENT/RGB input terminals. Y, Pb, Pr signals ⇒ "Y/PB/PR" R, G, B, HD, VD signals ⇒ "RGB"
Panasonic Auto (4:3)	Set to "4:3" if using the ASPECT-AUTO button function to view 4:3 images in an unchanged format. If you would like to view 4:3 images in "Just" format, set to "Just".
OSD Language	Select the on-screen display language (English/Deutsch/Français/Italiano/Español).

SERIAL terminal

The SERIAL terminal conforms to the RS-232C interface specification, so that the Wide Plasma Display can be controlled by a computer which is connected to this terminal.

You can control the Wide Plasma Display with a computer by using the TY-SCP02RS1U (optional accessory).

The computer will require software which allows the sending and receiving of control data which satisfies the conditions given below. Use a computer application such as a programming language to create the software. Refer to the documentation for the computer application for details.

Pin layout and signal names

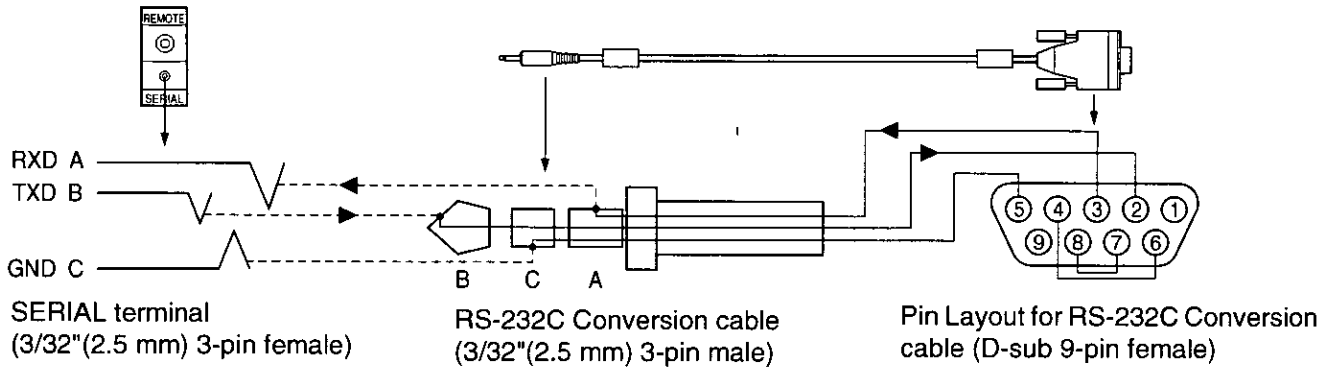

Communication parameters

Signal level	RS-232C compliant
Synchronization method	Asynchronous
Baud rate	9600 bps
Parity	None
Character length	8 bits
Stop bit	1 bit
X parameter	None
S parameter	None

The Wide Plasma Display (SERIAL terminal)		RS-232C Conversion cable		Computer
Details	3/32" (2.5 mm) dia. 3-pin female	3/32" (2.5 mm) dia. 3-pin male	D-sub 9-pin female	Details
TXD	B	B	②	RXD
RXD	A	A	③	TXD
GND	C	C	⑤	GND
		Shorted	④ ⑥	
		Shorted	⑦ ⑧	
		NC	① • ⑨	

Basic format for control data

The transmission of control data from the computer starts with an STX signal, followed by the command, the parameters, and lastly an ETX signal in that order. If there are no parameters, then the parameter signal does not need to be sent.

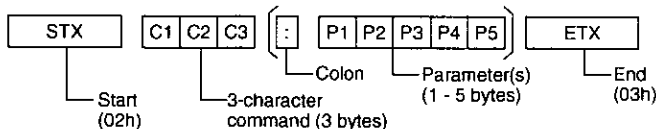

Note:











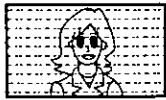

- (1) If multiple commands are transmitted, be sure to wait for the response for the first command to come from this unit before sending the next command.
- (2) If an incorrect command is sent by mistake, this unit will send an "ER401" command back to the computer.

Command



Command	Parameter	Control details
PON	None	Power ON
POF	None	Power OFF
AUU	None	Volume increase
AUD	None	Volume decrease
AMT	None	Mute (toggle)
IIS	None VID YP1 RG1	Input select (toggle) AV Mode Component/RGB mode (processed as a Y/PB/PR or RGB signal as set by this unit) PC mode
DAM	None NORM ZOOM FULL JUST SELF	Screen mode select (toggle) 4:3 Zoom1 16:9 Just Panasonic Auto

Troubleshooting

Before you call for service, determine the symptoms and make a few simple checks as shown below.

Symptoms		Checks
Picture	Sound	
 Interference	 Noisy Sound	Electrical Appliances Cars/Motorcycles Fluorescent light
 Normal Picture	 No Sound	Volume (Check whether the mute function has been activated on the Remote Control.)
 No Picture	 No Sound	Not plugged into AC outlet Not switched on Contrast and Brightness/Volume setting (Check by pushing the Power Switch or Stand-by Button on the Remote Control.)
 No Picture	 Normal Sound	If a signal with a non-applicable color system, format or frequency is input, only the input terminal indication is displayed.
 No Color	 Normal Sound	Color controls set at minimum level. Color System (Refer to page 29)
 Image too bright	 Normal Sound	A video signal has been connected to the AV output terminal by mistake. The input becomes high impedance, and the image becomes too bright. Connect video signals to the video input terminal.

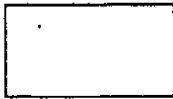
Plasma Display panel

Symptoms	Checks
 Some parts of the screen do not light up	The plasma display panel is manufactured using an extremely high level of precision technology, however sometimes some parts of the screen may be missing picture elements or have luminous spots. This is not a sign of a malfunction.
 Afterimages appear	If still video images or computer images are displayed for long periods of time, an afterimage may appear. In such cases, display an image which has some degree of movement in it to reduce having afterimages appear.

Specifications

Power Source

120 V AC, 50/60 Hz

Power Consumption

PT-42P1

Normal use: 380 W (Maximum Current 3.3 A)
Stand-by condition: 1.7 W
Power off condition: 0.7 W

PT-37P1

Normal use: 350 W (Maximum Current 3.0 A)
Stand-by condition: 1.7 W
Power off condition: 0.7 W

Plasma Display panel

PT-42P1

Drive method AC type
42-inch, 16:9 aspect ratio

PT-37P1

Drive method AC type
37-inch, 16:9 aspect ratio

Screen size

PT-42P1

36.2" (W) × 20.4" (H) × 41.6" (diagonal)
(920 mm (W) × 518 mm (H) × 1056 mm (diagonal))
No. of pixels
408,960 (852 (W) × 480 (H)) [2,556 × 480 dots]

PT-37P1

32.2" (W) × 18.1" (H) × 37" (diagonal)
(818 mm (W) × 461 mm (H) × 939 mm (diagonal))
No. of pixels
408,960 (852 (W) × 480 (H)) [2,556 × 480 dots]

Operating conditions

Temperature: 0°– 40°C
Humidity: 20% – 80%

Applicable signals

Color System: NTSC, PAL, PAL-60, SECAM
Scanning format: 525i, 525p, 625i, 625p, 1080i (720p signals cannot be displayed.)
PC signals: VGA, S-VGA (compressed), Horizontal scanning frequency 15.6 - 50 kHz

Connection terminals

AV	VIDEO IN (BNC)	1.0 Vp-p (75 Ω) (with 75 Ω or high-impedance auto select)
	S-VIDEO IN (Mini DIN 4-pin)	Y: 1 Vp-p (75 Ω), C: 0.286 Vp-p (75 Ω)
	AUDIO IN L-R (RCA pin jack × 2)	0.5 Vrms
	VIDEO OUT (BNC)	1.0 Vp-p (75 Ω) (bridge output)
COMPONENT/RGB	Y/G	1.0 Vp-p (including synchronization)
	P _B /B	± 0.35 Vp-p
	P _R /R	± 0.35 Vp-p
	HD	± 1.0 – 5.0 Vp-p
	VD	± 1.0 – 5.0 Vp-p
PC	AUDIO IN L-R (RCA pin jack × 2)	0.5 Vrms
	VIDEO (High-density D-sub 15-pin)	
SPEAKERS (8 Ω)	AUDIO	0.5 Vrms (1/8" (3 mm) mini jack)
SERIAL TUNER REMOTE	For TY-SP42P1U only. (For PT-42P1)	
	For TY-SP37P1U only. (For PT-37P1)	
	External control terminal	

Specifications

Accessories Supplied

Remote control Transmitter	TNQE177
Battery (2 × R6 (AA) Size)	
Ferrite core	TSK1027
Warranty	

Optional Accessories

Speakers	PT-42P1 TY-SP42P1U	PT-37P1 TY-SP37P1U
Pedestal	TY-ST42PT1U	TY-ST42PT1U
Wall stand	TY-ST42PW1U	TY-ST42PW1U
Mobile stand	TY-ST42PF1U	
Wall-hanging bracket (vertical)	TY-WK42PV1U	TY-WK42PV1U
Wall-hanging bracket (angled)	TY-WK42PR1U	TY-WK42PR1U
Ceiling unit	TY-CE42PS1U	TY-CE42PS1U
RS-232C Conversion cable	TY-SCP02RS1U	TY-SCP02RS1U
PC cable	TSX4515-3	TSX4515-3

Dimensions (W × D × H)

PT-42P1
40.6"(1030mm) × 25"(633.5mm) × 3.5"(89mm)

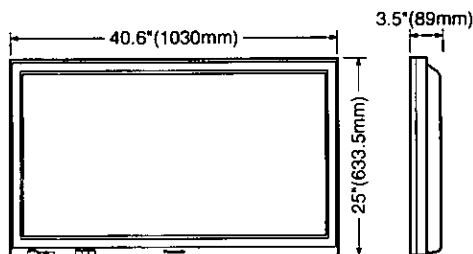

PT-37P1
36.6"(930mm) × 22.6"(573.5mm) × 3.5"(89mm)

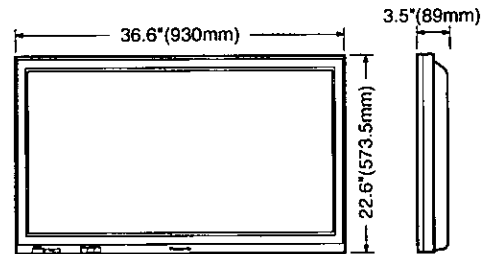

Weight (Mass)

PT-42P1
72.8 lb.(33.0kg) Net

PT-37P1
60.5 lb.(27.5kg) Net

Note:

Design and Specifications are subject to change without notice. Weight and Dimensions shown are approximate.

Trademark Credits

Macintosh is a U.S. registered trademark of Apple Computer Ltd.

PC-98 is a trademark of NEC Corporation.

All other trademarks mentioned in this manual are the property of their respective owners.

Sound "BBE" has been created under license from BBE Sound Incorporated.

BBE is a registered trademark of BBE Sound Incorporated.

Customer's Record

The model number and serial number of this product can be found on its rear cover. You should note this serial number in the space provided below and retain this book plus your purchase receipt as a permanent record of your purchase to aid in identification in the event of theft or loss, and for Warranty Service purposes.

Model Number _____

Serial Number _____

Panasonic Broadcast & Digital Systems Company

Division of Matsushita Electric Corporation of America

Executive Office :

3330 Cahuenga Blvd W., Los Angeles, CA 90068 (323) 436-3500

EASTERN ZONE : One Panasonic Way 4E-7 Secaucus, NJ 07094 (201) 348-7621

Mid-Atlantic/New England : One Panasonic Way 4E-7 Secaucus, NJ 07094 (201) 348-7621

Southeast Region : 1225 Northbrook Parkway, Ste 1-160 Suwanee GA 30024 (770) 338-6835

Central Region : 1707 N Randall Road E1-C-1, Elgin, IL 60123 (847) 468-5200

WESTERN ZONE : 3330 Cahuenga Blvd W., Los Angeles, CA 90068 (323) 436-3500

Dallas Region : 6226 Abington Way, Houston, TX 77008 (713) 802-2726

No. CA/Northwest Region : 5870 Stone ridge, #3, Pleasanton, CA (925) 416-5108

Government Marketing Department : 52 West Gude Drive, Rockville, MD 20850 (301) 738-3840

Panasonic Sales Company

Division of Matsushita Electric of Puerto Rico, Inc.

San Gabriel Industrial Park, 65th Infantry Ave., K.M.9.5, Carolina, PR 00630 (787) 750-4300

Panasonic Canada Inc.

5770 Ambler Drive, Mississauga, Ontario L4W 2T3 (905) 624-5010